

# General Specifications

## Models CA100SG/SN and 200SG/SN Capacitance Magnetic Flowmeter



GS 01E08B01-00E

ADMAG CA magnetic flowmeter is excellent at measurement in ultra-low conductivity fluids down to 0.01 $\mu$ S/cm, adhesive fluids, or slurry fluids. Since ADMAG CA employs a non-wetted electrode construction, picking up the signal voltage by electrode plates provided outside a ceramic pipe through the capacitance of the pipe.

### ■ FEATURES

- Non-wetted electrodes
  - Immune to adhesive or slurry fluids
  - Wide measurable range, minimum 0.01 $\mu$ S/cm of conductivity. (for size 15 to 100mm (0.5 to 4in.))
  - Leak Proof Electrode
- Excellent on corrosive fluid and abrasive fluid
  - Alumina ceramics (99.9%)
- Dual compartment housing separates the wiring section from the electronics and protects the electronics from corrosive environments.
- High visibility backlight LCD for easy operation
- High accuracy,  $\pm$ 0.5% of flow rate (size 25 to 100mm (1 to 4 in))



### ■ STANDARD SPECIFICATIONS

#### ■ Magnetic Flow Converter

- \* Note: For models with no indicator, a hand-held terminal is necessary to set parameters.
- \*\*Note:Pulse output and alarm output use common terminals, therefore these functions are not available at the same time.

#### Output Signal:

- Current Output: 4 to 20 mA DC
  - Load resistance 750 ohm maximum (250 to 600 ohm when communication)
- Transistor Contact Output: Pulse or alarm output selected by parameter setting (Contact rating: 30 V DC(OFF), 200mA(ON))

#### Communication (Optional) :

BRAIN (Superimposed on the 4 to 20 mA DC signal)

#### Conditions of Communication Line:

- Load Resistance: (including cable resistance) 250 to 600 ohm
- Load Capacitance: 0.22  $\mu$ F maximum
- Load Inductance: 3.3 mH maximum
- Distance from Power Line: 15 cm(0.6 ft) or more (Parallel wiring should be avoided.)
- Input Impedance of Receiver Connected to the Receiving Resistance: 10 k $\Omega$  or larger (at 2.4 kHz)
- Maximum Cable Length: 2 km(6500 ft) (when polyethylene - insulated PVC - sheathed control cables (CEV cables) are used)

#### Instantaneous Flow Rate Display Function:

Flow rate can be displayed either in engineering units or in percent of span.

(for models with indicator)

#### Totalizer Display Function:

Totalized volume in engineering units can be displayed by setting a totalizing factor. (for models with indicator)

#### Span Setting Function:

Volumetric flow setting is available by setting volume unit, time unit, flow rate value and flow tube size.

Volume Unit: gallon(US), m<sup>3</sup>, L, cm<sup>3</sup>, barrel (=158.987L)

Velocity Unit: ft, m

Time Unit: sec., min., hour, day

Flow Tube Size: inch, mm

#### Data Security During Power Failure:

Data storage in EEPROM - no back-up battery required.

#### Damping Time Constant:

Settable from 1 second to 200 seconds. (63% response time)

#### Pulse Output Function:

Scaled pulse can be output by setting a pulse factor.

Pulse Width: Duty 50% or fixed pulse width (0.5, 1, 20, 33, 50, or 100 ms) - user selectable.

Output Rate: 0.0001 to 1000pps (when pulse output function is selected.)

#### Alarm Output Function:

Indicates that an alarm occurs (Normal Close Fixed).

#### Self Diagnostics Function:

Converter failure, flow tube failure, erroneous setting, etc. can be diagnosed and displayed (for models with

indicator).  
**Electrical Connection:**  
 ANSI 1/2NPT female, DIN Pg13.5 female,  
 ISO M20 x 1.5 female, JIS G1/2 female.

**Terminal Connection:** M4 size screw terminal.

**Case Material:** Aluminum alloy.

**Coating:** Polyurethane corrosion-resistant coating.  
 Cover; Deep sea moss green (Munsell  
 0.6GY3.1/2.0).  
 Case; Frosty white (Munsell 2.5Y8.4/  
 1.2).

**Protection:** IP67, NEMA 4X

■ **Magnetic Flow Tube**

**Protection:** IP67, NEMA 4X

**Size in mm (inch):**

15 (0.5"), 25 (1"), 40 (1.5"), 50 (2"), 80 (3"), 100  
 (4"), 150 (6"), 200 (8")

**Coating:**

Size 15 to 100mm (0.5 to 4 in) : No coating  
 (Stainless steel surface)  
 Size 150, 200mm (6, 8 in) :  
 Polyurethane corrosion-resistant coating  
 Frosty white (Munsell 2.5Y8.4/1.2)

**Flow Tube Material:**

Housing: Stainless steel (15 mm: SCS11, 25 to  
 200 mm: SUS304)

**Wetted Part Material:**

Pipe: Alumina ceramics (99.9%)  
 Earth Ring:Stainless steel (SUS316), Hastelloy  
 C276 equivalent, Titanium

Note: • Hastelloy is a registered trademark of  
 Haynes International Inc.

**Gasket:**

- VALQUA#7020 : Fluoro resin PTFE with filler  
 (between flow tube body and earth ring)
- VALQUA#4010 : Fluoro rubber, viton (between  
 flow tube body and earth ring; for optional code /  
 FRG)
- Non-asbestos joint sheet sheathed with fluoro  
 resin PTFE (between earth ring and process  
 flange; for optional code / BCF or /BSF)
- Chloroprene rubber (between earth ring and  
 process flange; for optional code / BCC or /BSC)

Note; Other gaskets between flow tube body and  
 earth ring:

- VALQUA#7026 : corrosion resistance  
 gasket (Fluoro resin PTFE with carbon)
- VALQUA#4010 (Mixing#RCD970) : Alkali  
 resistance gasket for PVC piping  
 (Fluoro rubber)
- VALQUA#4010 (Mixing#RCD470) : Acid  
 resistance gasket for PVC piping  
 (Fluoro rubber)

Contact Yokogawa office. (Refer to TI  
 1E6A0-06E)

**Electrode Construction:** Non-wetted type.

**Grounding:** 100Ω or less

\* In case of JIS Flameproof type, JIS Class 3 (10Ωor  
 less)or JIS Class 1 (10Ωor less)

■ **HAZARDOUS AREA CLASSIFICA-  
 TION** (Only for size 15 to 100mm)

**FM:**

- Explosion proof for Class I, Division 1 Groups A,  
 B, C & D.
- Dust-ignition proof for Class II/III, Division 1

Groups E, F & G.

Temp.Class: T6

- Non incendive for Class I, Division 2 Groups A, B,  
 C & D Suitable for class II, Division 2, Group F &  
 G;Class III Division 1& 2

Temp.Class: T4A

Enclosure: NEMA 4X

Note: • Installation shall be in accordance with the  
 manufacturer's instructions and the National  
 Electric Code, ANSI/NFPA-70

**CSA:**

- Explosion proof for Class I, Groups B, C & D;  
 Class II Group E, F & G; Class III

Temp. Class T6 T5 T4

Process Temp. 70 85 120°C

Enclosure: Type 4

- Non incendive for Class I, Division 2 Groups A, B,  
 C & D; Class II Division 2, Group F & G; Class III

Temp.Class: T4A

Process Temp.:105°C

**JIS:**

- Construction: Exde II CT4X  
 : Converter, Terminal box; Explosion proof  
 Flow Tube ; Increased Safety  
 : Ignition and Explosion Class of gas or  
 vapour ; II CT4X
- Ambient Temperature : -20 to 50°C
- Fluid Temperature : 120°C or less
- Grounding : JIS Class 3(10Ω or less) or JIS Class  
 1(10Ω or less)

■ **STANDARD PERFORMANCE**

**Accuracy :**

Size 15 to 100mm (0.5 to 4in):  
 (fluid conductivity of 0.1μ S/cm or more)

Size in mm (inch)	Span in m/s (ft/s)	Accuracy
15 (0.5)	0.5 to 1 (1 to 3)	1.0% of span
	1 to 10 (3 to 33)	0.5% of span (at indications below 50% of span )
		1.0% of flowrate (at indications 50% of span or more)
25 to 100 (1 to 4)	0.5 to 1 (1 to 3)	0.5% of span
	1 to 10 (3 to 33)	0.25% of span (at indications below 50% of span)
		0.5% of flowrate (at indications 50% of span or more)

Size 150, 200mm (6, 8in):  
 (fluid conductivity of 1μ S/cm or more)

Size in mm (inch)	Span in m/s (ft/s)	Accuracy
150, 200 (6, 8)	0.5 to 1 (1 to 3)	1.0% of span
	1 to 10 (3 to 33)	0.5% of span (at indications below 50% of span )
		1.0% of flowrate (at indications 50% of span or more)

Fig1.eps

**Repeatability:**

0.1% of flow rate (Minimum 1mm/s)

**Maximum Power Consumption:**

14W ( for combination of flow tube and converter)

**Insulation Resistance:**

- 100M ohm between power terminals and ground terminal at 500 V DC.
- 100M ohm between power terminals and each output terminal at 500 V DC.
- 20M ohm between each output terminal and ground terminal at 100 V DC.

**Withstanding Voltage:**

- 1500 V AC for 1 minute between power terminals and ground terminal.

**CAUTION**

When performing the Voltage Breakdown Test, Insulation Resistance Test or any unpowered electrical test, wait 10 seconds after the power supply is turned off before removing the housing cover. Be sure to remove the Short Bar at terminal "G". After testing, return the Short Bar to its correct position. Screw tightening torque should be 12kgf·cm(0.88ft·lb) or more, because the G-terminal is thought as a protective grounding and should conform to the Safety Requirements.

**EMC Conformity Standard:**

AS/NZS 2064

**NORMAL OPERATING CONDITIONS**

**Ambient Temperature:** -20 to 50°C (-4 to 122°F)

**Ambient Humidity:** 5 to 80%RH (no condensation)

**Power Supply :** -A1; Range 80 to 264 V AC, 47 to 63Hz/ 100 to 130VDC, -D1; Range 20.4 to 28.8VDC

**Supplied Power and Max. Cable Length for 24V DC version:**

Allowed cable length m (ft)

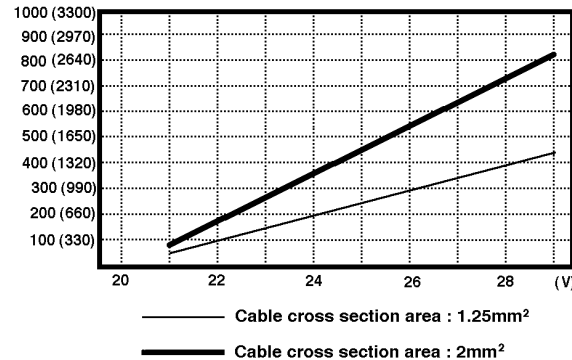

**Grounding:** 100 Ω or less

**Measurable Fluid Conductivity:**

- Size 15 to 100mm (0.5 to 4 in): 0.01μS/cm or more
  - Size 150, 200mm (6,8 in): 1μS/cm or more
- \* In case of size 15 to 100mm (0.5 to 4 in) for fluid of which conductivity is from 0.01μS/cm to 0.1μS/cm, refer to accuracy in the figure below.

**Measured Data for Reference:**

**Measured Condition**

- Size : 25mm(1 in.)
- Fluid name : Glycerin + Ethylene glycol
- Viscosity : 30cSt
- Flow velocity : 1m/s
- Damping : 3sec
- Measured Time : 20sec

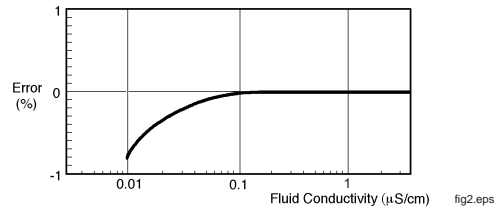

**Piping Conditions:**

- Piping should be designed to ensure a full pipe. ADMAG CA does not employ an empty detection circuit, and an empty pipe condition can result in an erratic output.
- For fluids which have large flow noise(pure water, pure alcohol or others), low conductivity or low viscosity, design the upper stream straight length which is over 20D(If impossible, contact Yokogawa office). Be careful not to protrude the gasket into the piping. Flow velocity in the range below is available.

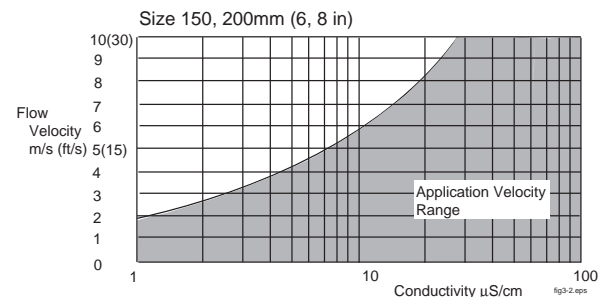
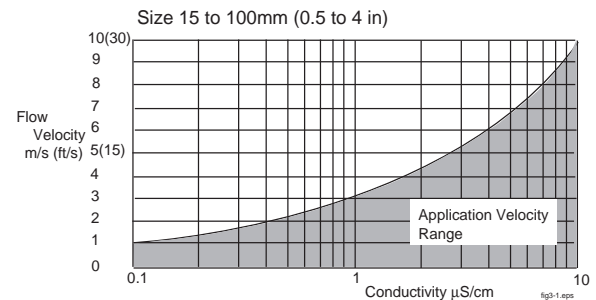

**Measurable Flow Range:**

SI Units (Size : mm, Flowrate : m<sup>3</sup>/h)

Size	Min. Range @0.5m/s	Max. Range @10m/s
15	0 to 0.3181	0 to 6.361
25	0 to 0.8836	0 to 17.671
40	0 to 2.2620	0 to 45.23
50	0 to 3.535	0 to 70.68
80	0 to 9.048	0 to 180.95
100	0 to 14.138	0 to 282.74
150	0 to 31.81	0 to 636.1
200	0 to 56.55	0 to 1,130.9

English Units (Size : inch, Flowrate : GPM)

Size	Min. Range @1.6ft/s	Max. Range @33ft/s
0.5	0 to 1.0040	0 to 20.078
1	0 to 4.016	0 to 80.31
1.5	0 to 9.036	0 to 180.70
2	0 to 16.063	0 to 321.2
3	0 to 36.15	0 to 722.8
4	0 to 64.26	0 to 1,285.0
6	0 to 144.57	0 to 2,891.3
8	0 to 257.01	0 to 5,140

T01.EPS

**Reasonable Figures for Thermal Shock of Ceramic Pipe:**

Size 15, 25mm (0.5, 1in)

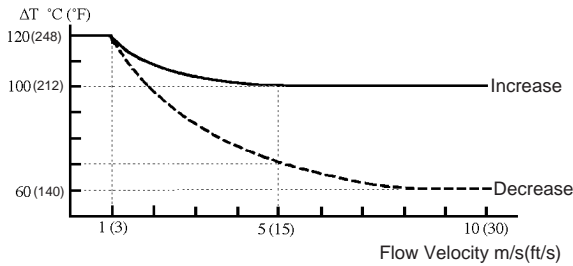

Size 40, 50mm (1.5, 2in)

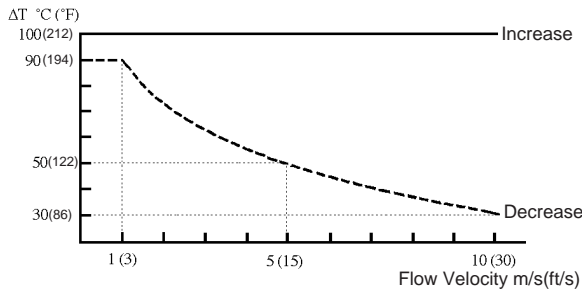

Size 80 to 200mm (3 to 8 in)

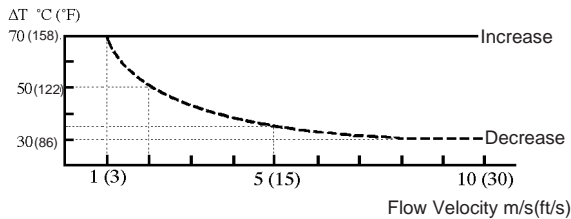

**Fluid Temperature and Pressure:**

Pressure MPa(kgf/cm<sup>2</sup>){PSi} ——— Size 15 to 50mm(0.5" to 2")  
 - - - - - Size 80 to 200mm(3" to 8")

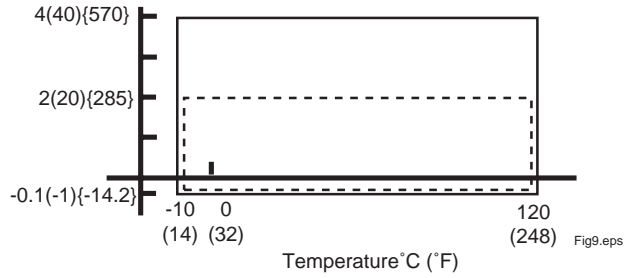

Fig9.eps

NOTE: This limits show maximum allowable fluid pressure for Flow Tube it self. Further fluid pressure should also be limited according to flange rating.

**MODEL AND SUFFIX CODES**

Model	Suffix Code	Description
CA115S	.....	Size 15mm(0.5")
CA202S	.....	Size 25mm (1")
CA204S	.....	Size 40mm (1.5")
CA205S	.....	Size 50mm (2")
CA208S	.....	Size 80mm (3")
CA210S	.....	Size 100mm (4")
CA215S	.....	Size 150mm (6")
CA220S	.....	Size 200mm (8")
Use	G .....	General purpose type
	N .....	FM/CSA Explosion proof type (Only for size 15 to 100mm)**
	C .....	JIS Flameproof type (Only for size 15 to 100mm)**
Pipe	-C .....	Ceramics
Process Connection	K1 .....	JIS 10K wafer
	K2 .....	JIS 20K wafer
	B1 .....	ANSI 150 wafer
	B2 .....	ANSI 300 wafer
	E2 .....	DIN PN10/16 wafer
	H1 .....	JIS F12(75M) wafer *
Electrode material	-N .....	Always N
Earth ring material	S .....	SUS316
	H .....	Hastelloy C276 equivalent
	V .....	Titanium
Electrical connection (Note 2)	J .....	JIS G1/2 (PF1/2) female**
	A .....	ANSI 1/2NPT female***
	D .....	DIN Pg13.5 female
	M .....	ISO M20X1.5 female
Power supply	-A1 .....	80 to 264V AC / 100 to 130V DC
	-D1 .....	20.4 to 28.8V DC
Indicator (Note 1)	DH .....	Horizontal (7 Segment LCD)
	DV .....	Vertical (7 Segment LCD)
	N .....	None
Optional specification	/ □	

T03.EPS

- \* : H1 is only for size 80 to 200mm.
- \*\* : Select JIS G1/2 female electrical connection (code J) and optional code /JF3 with /G11 or /G12 in case of requirement of JIS Flameproof type.
- \*\*\* : Select ANSI 1/2 NPT female electrical connection(code A) in case of requirement of FM/CSA explosion proof type.

**Note 1**

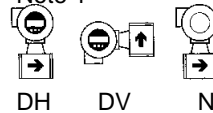

## OPTIONAL SPECIFICATIONS

A : Available N : Not available

ITEM	Specification	Use			Code
		General Purpose	Ex.Proof		
		CA***SG	CA***SC	CA***SN	
Waterproof Gland	Waterproof Glands are attached to Power and signal wiring ports. For JIS G1/2 only.	A	N	N	/ECG
Waterproof Gland with Union Joint	Waterproof Glands(union joint) are attached to Power and signal wiring ports. For JIS G1/2 only.	A	N	N	/ECU
Gasket for PVC pipe	Gaskets are attached between earth ring and flow tube.	A	A	A	/FRG
Lightning Protector	Built-in Lightning Protector(Only for 24VDC version)	A	A	A	/A
BRAIN Communication	Digital communication with BRAIN protocol	A	A	A	/BR
Epoxy Coating	Coating is changed to Epoxy coating.	A	A	A	/EPF
High Anti-corrosion Coating	Coating is changed to three-layer coating (Urethane coating on two-layer epoxy coating)	A	A	A	/X2
Material Certificate	Reproduced material certificate for mini-flange and earth ring.	A	A	A	/M01
Bolt & Nut Assembly (Note 1)	Carbon steel bolts/nuts and chloroprene gaskets assembly.	A	A	A	/BCC
	Carbon steel bolts/nuts and non-asbestos PTFE-wrapped gaskets assembly.	A	A	A	/BCF
	Stainless steel bolts(SUS304)/nuts(SUS403) and chloroprene gaskets assembly.	A	A	A	/BSC
	Stainless steel bolts(SUS304)/nuts(SUS403) and non-asbestos PTFE-wrapped gaskets assembly.	A	A	A	/BSF
JIS Flameproof (Note 2) (Note 3)	JIS Flameproof type	N	Note3	N	/JF3
Flameproof Packing Adapter for JIS Flameproof(Note 3)	One Flameproof Packing Adapter and a blind plug are attached.	N	Note3	N	/G11
	Two Flameproof Packing Adapters are attached.	N	Note3	N	/G12
FM Approval (Note 2)	FM Explosion proof/FM Non-incendive type	N	N	A	/FF1
CSA Certification (Note 2)	CSA Explosion proof/CSA Non-incendive type	N	N	A	/CF1
GOST Certificate	Calibration Certificate for GOST (Only for products produced at YFT)	A	N	A	/GOS
Mirror Finished Ceramics	Mirror Finishing on the inside of ceramic tube (Rmax. <= 1micro-meter)	A	A	A	/MRR
180deg. Rotate Converter	180deg. rotate converter for reversed flow direction	A	A	A	/CRC
Oil-prohibited Use	Degreased cleansing treatment	A	A	A	/K1
Oil-prohibited Use with Dehydrating Treatment	Degreased cleansing treatment; Packing with desiccant	A	A	A	/K5
Hydrostatics Test Certificate	Test pressure depends on process connection (Test duration 10minutes) Test result is full in NOTE of QIC.	A	A	A	/T01
Calibration Certificate	Level2: Declaration and Calibration Equipment List	A	A	A	/L2
	Level3: Declaration and Primary Standard List	A	A	A	/L3
	Level4: Declaration and YOKOGAWA Measuring Instruments Control System	A	A	A	/L4

T02.EPS

Note 1: It is available only for JIS 10K wafer, JIS 20K wafer or ANSI 150 wafer type.

2: It is available only for size 15 to 100mm (0.5 to 4 in).

3: Select optional code /JF3 with /G11 or /G12 in case of requirement of JIS Flameproof type.

/G11 is selectable only for DC power supply and 4-conductor cable use.

## TERMINAL CONNECTION

Terminal Symbols	Description
P+ P- I+ I- L+ N- 	<input type="checkbox"/> Pulse or Alarm output <input type="checkbox"/> Current output 4 to 20mA DC <input type="checkbox"/> Power and protective grounding

T04.EPS

## ACCESSORIES

Fuse (2A 250V) 1  
 Data sheet 1  
 Unit labels 1  
 Centering device 1set  
 Hexagonal Wrench(in case of ex-proof) 1

■ SIZING DATA

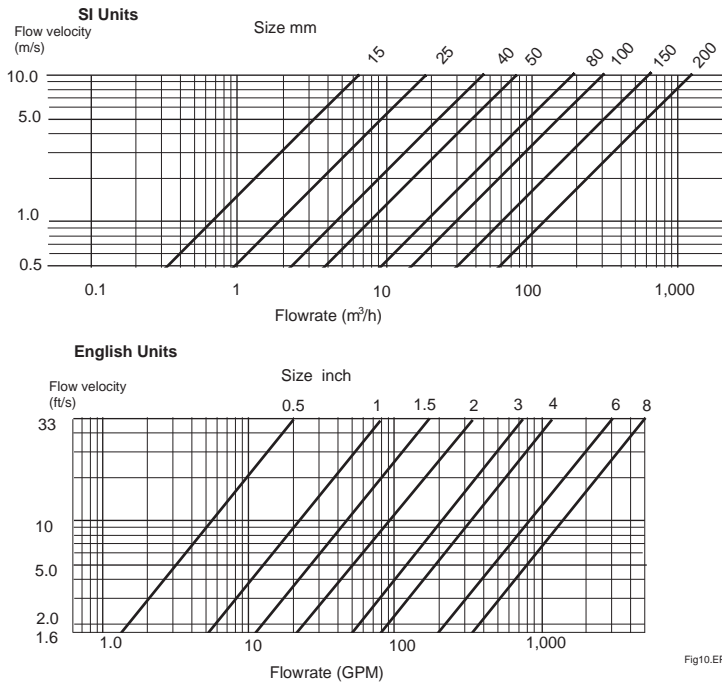
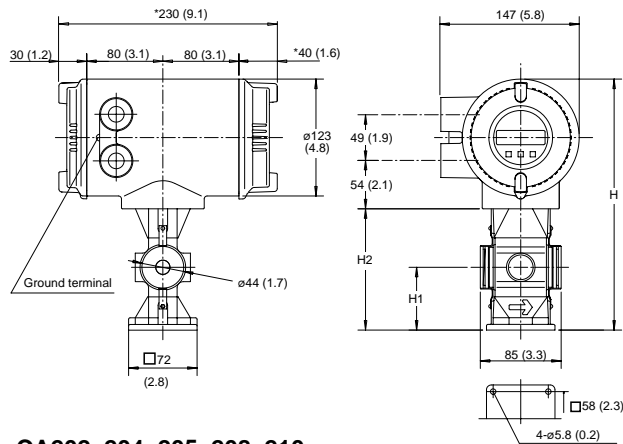

Fig10.EPS

Note: Measurable flow velocity is from 0m/s.

■ EXTERNAL DIMENSIONS

• CA115



CA115S

Type		General (G)	Ex-proof (N/C)
Size code		115	
Size		15 (0.5)	
Lining		Ceramics	
Height	H	267.5 (10.5)	265 (10.4)
Height	H1	66 (2.6)	66 (2.6)
Height	H2	127.5 (5.0)	125 (4.9)
Weight	kg (lb)	4.7 (10.4)	4.7 (10.4)

Fig. 12

\* The length marked as \* is shorter by approx. 10 mm (0.4") for non indicator type.

• CA202, 204, 205, 208, 210

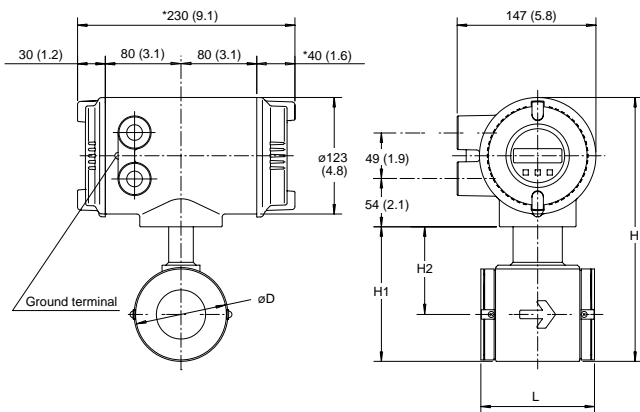

CA202S  
204  
205  
208  
210

Type		General (G)					Ex-proof (N/C)				
Size code		202	204	205	208	210	202	204	205	208	210
Size		25 (1.0)	40 (1.5)	50 (2.0)	80 (3.0)	100 (4.0)	25 (1.0)	40 (1.5)	50 (2.0)	80 (3.0)	100 (4.0)
Lining		Ceramics									
Face to face length	L	93 (3.7)	106 (4.2)	120 (4.7)	160 (6.3)	180 (7.1)	93 (3.7)	106 (4.2)	120 (4.7)	160 (6.3)	180 (7.1)
Outer diameter	D	67.5 (2.7)	86 (3.4)	99 (3.9)	129 (5.1)	155 (6.1)	67.5 (2.7)	86 (3.4)	99 (3.9)	129 (5.1)	155 (6.1)
Height	H	250.6 (9.9)	271 (10.7)	283.5 (11.2)	313.5 (12.3)	349.5 (13.8)	248.6 (9.8)	269 (10.6)	281.5 (11.1)	311.5 (12.3)	347.5 (13.7)
Height	H1	110.6 (4.4)	131 (5.2)	143.5 (5.6)	173.5 (6.8)	209.5 (8.2)	108.6 (4.3)	129 (5.1)	141.5 (5.6)	171.5 (6.8)	207.5 (8.2)
Height	H2	76.8 (3.0)	87.5 (3.4)	94 (3.7)	109 (4.3)	132 (5.2)	74.8 (2.9)	85.5 (3.4)	92 (3.6)	107 (4.2)	130 (5.1)
Weight	kg (lb)	4.6 (10.1)	5.5 (12.1)	6.5 (14.3)	9.2 (20.3)	12.3 (27.1)	4.6 (10.1)	5.5 (12.1)	6.5 (14.3)	9.2 (20.3)	12.3 (27.1)

Fig. 13

\* The length marked as \* is shorter by approx. 10 mm (0.4") for non indicator type.

• CA215, 220

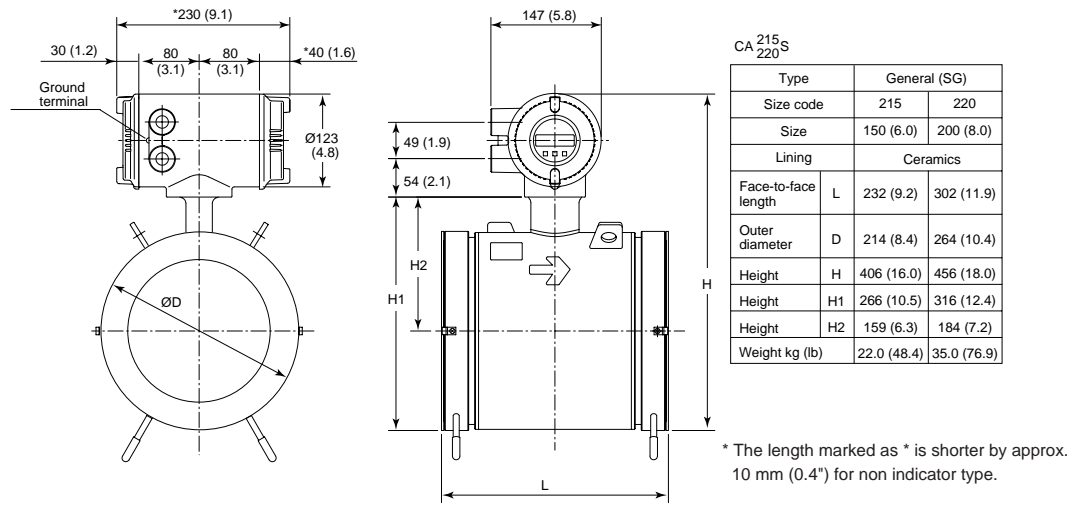
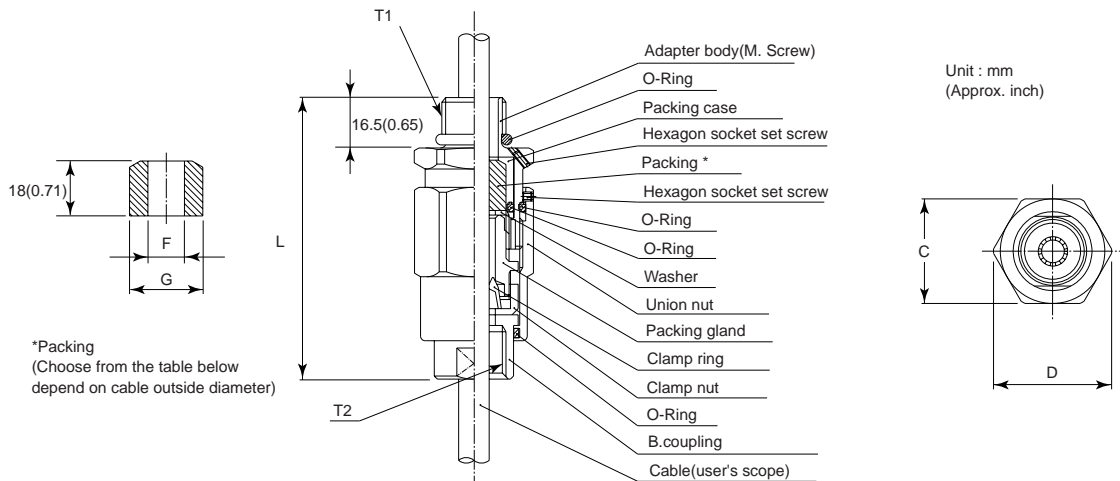

Fig. 14

JIS Flameproof Packing Adapter /G11, /G12



Dimension					Cable outer diameter	Packing diameter		Identification mark	Weight kg (lb)
T1	T2	C	D	L		F	G		
G 1/2	G 1/2	35 (1.38)	39 (1.54)	94.5 (3.72)	φ8.0 to φ10.0 (0.31 to 0.39)	φ10.0(0.39)	φ20.0	16 8-10	0.26 (0.57)
					φ10.0 to φ12.0 (0.39 to 0.47)	φ12.0(0.47)	(0.79)	16 10-12	

■ EARTH RING INSIDE DIAMETER

Unit : mm (inch)

Size	EARTH RING INSIDE DIAMETER	
15(0.5)	15	(0.6)
25(1)	27	(1.1)
40(1.5)	40	(1.6)
50(2)	52	(2.1)
80(3)	81	(3.2)
100(4)	98	(3.9)
150(6)	144	(5.7)
200(8)	192	(7.6)

\* Please be sure the inner diameter of a gasket does not protrude to the earth ring inside diameter.

T05.EPS

■ GASKET

Please use compressed non-asbestos fiber gasket, PTFE gasket or the gasket which has equal elasticity. In case of optional code/FRG, please use rubber gasket or others which has equal elasticity.

=== ORDERING INFORMATION ===

1. Model, specification and optional codes.
2. Fluid name.
3. Parameter setting.
  - (1) Flow rate span (at 100% of the flow rate)  
Example: Volume/Time unit
  - (2) Totalizing pulse units  
Example: Volume/Pulse, Pulse/Time unit
  - (3) Transmission pulse units (Only with pulse output)  
Example: Volume/Pulse, Pulse/Time unit

=== RELATED INSTRUMENTS ===

Related Product  
 Calibrator for magnetic flowmeter  
 (AM012) .....GS 01E06K02-00E  
 BT200 Brain Terminal ..... GS 1C0A11-E